



111-300 Series Transformer Temperature Monitor

The most accurate, low-cost temperature monitor

Advanced winding temperature algorithms



111-300 Series Transformer Temperature Monitor

The 111-300 Series Transformer Temperature Monitor provides more accurate information so you can make better decisions regarding your equipment. Utilizing microprocessor technology and advanced thermal modeling it economically monitors oil and winding temperatures within liquid-cooled transformers. Comprised of one or two independent, single-channel digital monitors housed in a weatherproof enclosure, the 111-300 accurately measures both liquid and winding temperatures using only one liquid well, which makes it extremely easy to install and use.

Advanced algorithms accurately model winding temperature behavior considering cooling mode, thermal time constant and temperature rise caused by load current. A more precise measure of winding insulation temperature allows for heavier loading and extended transformer life.

The 111-300 displays present and maximum stored temperatures, and provides relays for fan alarm and trip controls. As an option, data communications are available through either milliamp (mA) loop outputs or RS485 MODBUS protocol.

The Qualitrol Series 111-300 provides both automatic and manual fan control, a fan exerciser to automatically and periodically operate the fans, and a test function for

complete reliability. Automatic cooling-bank switching evens out wear and prolongs the life of the cooling bank's fans and pumps. By simply snapping a small Current Transformer (CT) around the conductor of your transformer CT, the 111-300 also provides a seamless upgrade for transformer temperature monitoring.

Standard features include a Universal Power Supply that covers most substation voltage ranges and user-friendly setup software and it can be supplied with non-intrusive, easy-to-retrofit sensors. Switch setpoints can be changed via the front panel.

The 111-300 Series Transformer Temperature Monitor offers:

- Extended transformer life
- Increased and improved transformer loading
- Easy installation and use
- Accuracy and durability in harsh substation conditions



Automation made easy





Extended transformer life

Several factors can reduce a transformer's efficiency: organic paper insulation that deteriorates over time at elevated temperatures; poorly modeled winding temperatures or slowly activated cooling that can lead to elevated temperatures; reduced fan and/or oil pump life due to inappropriately switching the cooling system on and off.

- Winding temperatures can be programmed for accurate representation of the winding "rise" (gradient), winding time constant, and the load current "exponent."
- Different parameters can be set for each of the possible cooling modes (ONAN, ONAF, OFAF, ODAF designations for natural convection, forced or directed air and oil cooling). During operation, the 111-300 can dynamically alter the parameters to match the present cooling mode.
- Automatic cooling bank switching evens out wear and prolongs the life of the cooling bank's controls, fans and pumps.
- A fan exerciser operates the cooling system at predetermined intervals to avoid motor seizure.

Increased and improved transformer loading

Improve transformer loading decisions through more accurate temperature modeling.

- The 111-300's inherent measurement accuracy is two times better than prior generation monitoring devices, meaning that the transformer can be operated at higher loads. Less contingency for accuracy error is needed, translating directly to substantially increased operating revenue and savings from deferred capacity upgrades.

Easy installation and use

- The self-contained weatherproof enclosure mounts directly to the outside of a transformer.
- Load current inputs are sampled by snapping a small CT around the conductor of the transformer CT. This provides total isolation of the monitoring system from the transformer system.
- Crucial measurement information is displayed without pushing any buttons. Front panel controls can be operated easily—even while wearing gloves.
- For retrofit applications, universal RTD probes offer unparalleled convenience. Unlike other systems that often require intrusive sensor installations, or sacrifice accuracy by trying to substitute surface sensors, these universal probes insert into virtually any existing thermal well.
- The 111-300 incorporates a totally universal power supply. It connects to any substation power, with a voltage range from 80-265 VAC or 20-280 VDC. This minimizes inventory, simplifies control wiring design and helps eliminate damage due to incorrect wiring or voltages.
- Computer-aided programming simplifies the setup of operating parameters.

Accuracy and durability in harsh substation conditions

- Measurement accuracy is held across the complete range of environmental and power-supply extremes.
- The 111-300 withstands the hostile electromagnetic environment of the substation. Protection from electrical surges and radio frequency interference is designed into the device. It meets the stringent performance requirements stipulated by the IEEE for protective relay devices and by CE to meet European norms.
- Self-diagnostic functions continuously test the internal circuitry, processor system and external sensors. External circuitry to the microprocessor is a "watchdog" on the processor system itself. If an abnormal condition is detected the 111-300 will place the transformer in a safe condition (fans and alarm on) and continue to function without false tripping.

Technical Specifications

Performance	Input Power:	Universal, 80 to 265 VAC or 20 to 280 VDC
	Power Dissipation:	2 Watts
	Temperature Sensors (Oil):	Universal probe 100 ohm RTD (optional)
	Temperature Sensors (Winding):	Clamp-on CT, 0 - 5A, 0 - 10A, 0 - 20A and others available (optional)
	Measurement Range:	0 - 200°C
	Display Resolution:	1°C increments
	Accuracy:	± 1% (2°C)
	Memory Retention:	Permanent
	Continuous Diagnostics:	Sensors, power and instrument circuitry
	Indicators:	Current temperature, maximum temperature, and activated relays
	Display:	Extended temperature range LCD
Outputs	Relays:	Up to eight SPDT contacts rated at 5A @ 250 VAC resistive
	Analog SCADA Output:	0 - 1 mA into 10,000 ohms max. or 4 - 20 mA into 500 ohms max.
	RS232:	Configuration port
	RS485:	MODBUS protocol (optional)
Environmental	Operating Temperature:	-30 to +72°C
	Storage Temperature:	-50 to +85°C
	Relative Humidity:	90% (non-condensing)
	Hi-pot:	2300 VAC for 1 minute all power and relay contacts to sensor terminals and earth ground
	Vibration:	60 to 120 Hz. @ .004 inch displacement
	Shock:	10g in 3 orthogonal planes
	Electrical Immunity:	(SWC) per IEEE C37.90.1 and per CE/IEC EN580081-2 (emissions), EN61000-6-2-2 (immunity), EN61010-1 (safety)
Mechanical	Weatherproof Enclosure:	UV stabilized, NEMA 3R fiberglass enclosure
	Front Panel Membrane:	UV stabilized polyester
	Weight:	Approx. 6.5 lb. (2.9 kg)



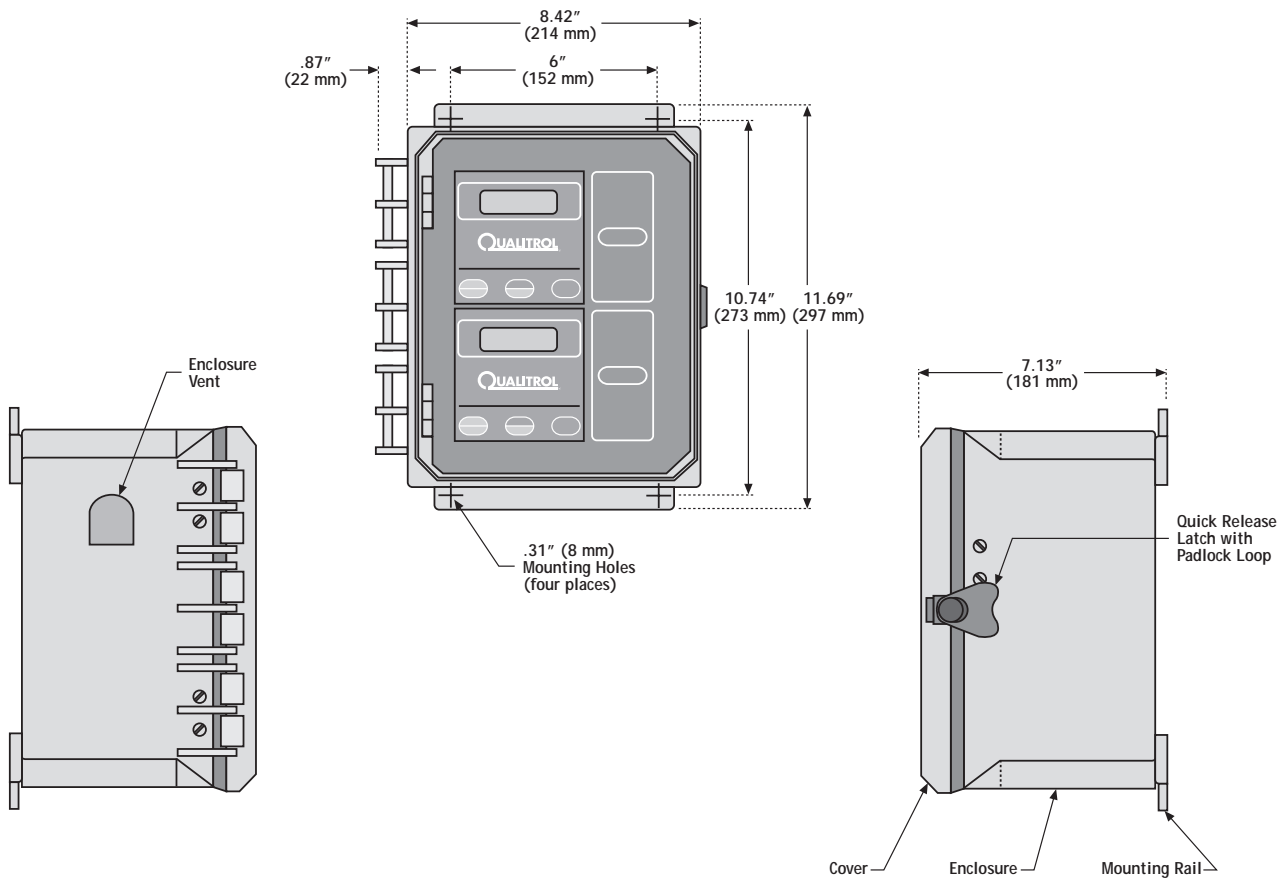

**111-300 Series
Transformer
Temperature Monitor
Ordering Information**

- 111-300-1 One Channel-Winding
- 111-300-2 One Channel with Analog Output-Winding
- 111-300-3 One Channel with MODBUS Output-Winding
- 111-300-4 One Channel with Analog & MODBUS Output-Winding
- 111-300-5 Two Channel-Liquid & Winding
- 111-300-6 Two Channel with Analog Output-Liquid & Winding
- 111-300-7 Two Channel with MODBUS Output-Liquid & Winding
- 111-300-8 Two Channel with Analog and MODBUS Output-Liquid & Winding



1385 Fairport Road
Fairport, New York 14450
USA

Phone: 585-586-1515
Fax Orders: 585-377-0220
Fax Quotes: 585-377-9613

E-mail: info@qualitrolcorp.com
www.qualitrolcorp.com

Flygfältsgatan 6C
S - 128 30 Skarpnäck
Sweden

Phone: +44 8 447 54 50
Fax: +44 8 604 68 10

